

LUXUL

WIRELESS

PRO-WAV™ 200

WI-FI RANGE EXTENDER SYSTEM QUICK INSTALL GUIDE



FC
FCC
CERTIFIED

NETGEAR®
WG103 AP Included

Congratulations on your purchase of the Luxul Pro-WAV™ Range Extender System! You are just minutes away from enjoying the benefits of a farther reaching, clearer wireless signal in your home or office.

LUXUL WIRELESS PRODUCTS COVERED BY THIS GUIDE

PW200-24-FC2 - Pro-WAV 1W 2.4GHz indoor Wi-Fi Range Extender System

LUXUL

WIRELESS

PRO-WAV™ 100 WI-FI RANGE EXTENDER SYSTEM

MODEL NUMBER: PW200-24-FC2

© 2010 by Luxul Wireless Inc. All rights reserved

No part of this publication may be modified or adapted in any way, for any purposes without permission in writing from Luxul Wireless, Inc. (Luxul). The material in this manual is subject to change without notice. Luxul reserves the right to make changes to any product to improve reliability, function, or design. No license is granted, either expressly or by implication or otherwise under any Luxul Wireless, Inc., intellectual property rights. An implied license only exists for equipment, circuits and subsystems contained in Luxul products.

This product is covered by one or more U.S. and foreign patents.

Patents: 7,783,270, 7,379,717, 6,606,075, 6,373,448, other patents pending

SHOCK-WAV™ WI-FI SIGNAL BOOSTER

MODEL NUMBER: PW-FC2

FCC ID: W59PWFC2

IC: 8584A-PWFC2

Luxul Wireless, Inc.

357 South 670 West, Suite 160

Lindon, UT 84042

www.luxulwireless.com

NETGEAR®

MODEL NUMBER: WG103

FCC ID: PY308400097

IC: 4054A-08400097

NETGEAR, Inc.

350 East Plumeria Drive

San Jose, California 95134-1911

www.netgear.com

PROFESSIONAL INSTALLATION CONSIDERATIONS

The Luxul Wireless Pro-WAV Wi-Fi Range Extender System is required to be professionally installed. The following components are approved for use in the system.

- Luxul Wireless Shock-WAV PW-FC2 Wi-Fi Signal Booster
- Luxul Wireless X-WAV™ XW-24-FP7 Flat Panel Antenna
- Netgear ProSafe WG103 Access Point
- Netgear Omni antenna included with WG103 access point

The output power of the amplifier is set and tested during manufacturing. There are no user modifiable parameters in the amplifier. The Luxul Shock-WAV Wi-Fi Signal Booster system incorporates a Digital AGC (D-AGC) that ensures a consistent and approved output power.

QUICK INSTALL GUIDE

THE PRO-WAV RANGE EXTENDER INCLUDES THE FOLLOWING:

- Metal Enclosure with space for mounting the AP (Access Point) internally
- Shock-WAV™ 802.11b/g Signal Booster
- Two X-WAV™ CP (Circularly Polarized) Antennas
- Three Ethernet cables
- Three Coax cables
- POE (Power-Over-Ethernet) Injector
- 48VDC Universal Input Power Supply
- Mounting Hardware
- Ethernet Pass Through
- Signal Splitter
- Barrel Connector
- Velcro
- Quick Install Guide
- Netgear ProSafe Access Point.
 - Included with the Netgear is: a Detachable Antenna, Ethernet Cable, Power Supply, Installation Guide, Warranty/Support Information Card and Resource CD.

ADDITIONAL ITEM REQUIRED

External Ethernet cable from your data/network source (Max. length 329' or 100 meters).

OPTIONAL EQUIPMENT

- HDW-PWM - Optional drop ceiling mounting arms for Pro-WAV systems

CONFIGURE YOUR AP

See the guide included with your AP and configure the AP before you connect the Luxul Range Extender System. Once the AP is configured, disconnect all power and connect the Luxul Range Extender System.



CAUTION: Disconnect all power before connecting or disconnecting any cables or coax to or from this device. Failure to do so will void your warranty.

LUXUL WIRELESS

ASSEMBLE THE RANGE EXTENDER SYSTEM

1. Connect the two X-WAV antennas to the antenna mount. Position the antennas so the N connectors are above the antenna mount (Figure 1).
2. Attach the antenna mount to the top of the enclosure using the washers and nuts provided.
3. If mounting the Pro-WAV 200 high in your Wi-Fi coverage area the antenna mount may be bent slightly downward to focus signal into the desired coverage area
4. Mount the AP to the enclosure using the included Velcro mounting strips.

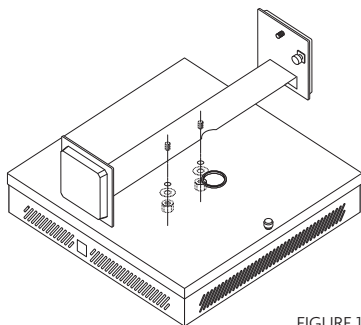

FIGURE 1

WIRING THE RANGE EXTENDER SYSTEM

1. Remove the stock antenna from your AP. Set aside the stock antenna, you will not need it for this installation.
2. Find the N Male to RP-SMA coax connected to the side of the Shock-WAV Wi-Fi Signal booster labeled “AP” (Figure 3) and connect it to the antenna port of your AP.
3. Find the N Male to N Male coax cables connected to the splitter that is attached to the Shock-WAV Wi-Fi Signal Booster on the side labeled “Antenna” (Figure 3).
4. Feed the coax cables through the round pass through hole in the top of the enclosure, (Figure 2) and connect them to the X-WAV antennas.

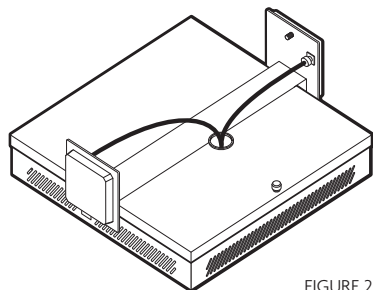

FIGURE 2

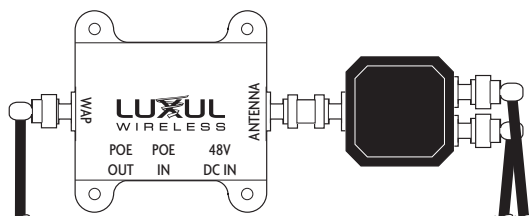

FIGURE 3

QUICK INSTALL GUIDE

POWERING OPTIONS

For maximum flexibility you may power the Pro-WAV Range Extender System by Direct Power or POE using the Luxul Wireless POE Injector or a POE injector that supports legacy mode. The Luxul Wireless Signal Booster does not support 802.3af POE power. (Check POE's documentation).

1. Decide where your Ethernet source will enter the Pro-WAV enclosure, left, right or bottom, and place the Ethernet pass through in that location.
2. **DO NOT** connect your external Ethernet source or power source at this time.

Direct Power: (Figure 4)

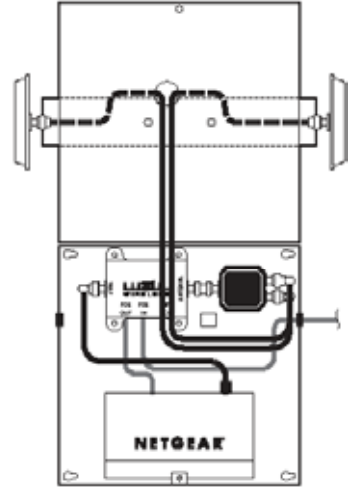

FIGURE 4



NOTE: If powering the Shock-WAV Signal Booster directly the "POE OUT" port is disabled.

1. Connect the Ethernet cable from the Ethernet pass through to the "10/100M" port of your Netgear AP, (See AP's documentation).
2. Attach the Luxul power supply (48VDC) to the "48V DC IN" port of the Signal Booster.
3. Connect Netgear power supply to the AP's power port (See AP's documentation).
4. Plug the power supplies into your power source.

Optional POE (Power Over Ethernet) (Figure 5)

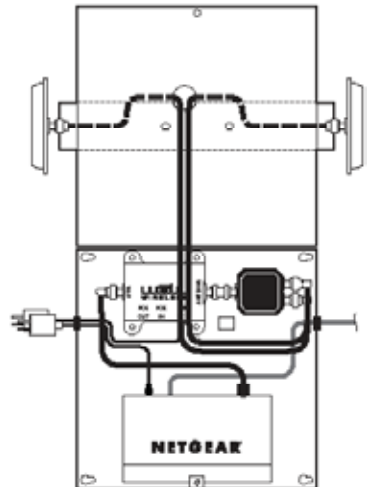

FIGURE 5

1. Connect the Ethernet cable from the Ethernet pass through to the "48V POE IN" port of the Wi-Fi Signal Booster.
2. Connect the next Ethernet cable from the "POE OUT" of the Wi-Fi Signal Booster to the "10/100M" port of your Netgear AP, (See AP's documentation).
3. Be sure all cables are connected securely and power up your POE injector.
4. You may now power your POE injector.

LUXUL WIRELESS

Optional POE with the POE-1Port Injector (Figure 4)

Install the optional POE injector where you have access to your data/network source Ethernet cable and power sources.

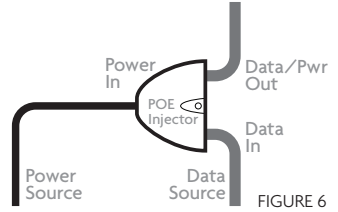

FIGURE 6



NOTE: The POE-1Port is a non 802.3af/ at compliant injector

DEPLOYMENT

The Pro-WAV 200 System features high gain directional antennas. Remember to consider the direction of the signal when positioning the enclosure. The signal extends out in both directions from the antennas mounted on the sides of the enclosure. If mounting the Pro-WAV 200 high in your Wi-Fi coverage area the antenna mount may be bent slightly downward to focus coverage. Use Figure 6 and 7 below to position your Pro-WAV 200 system for maximum Wi-Fi coverage.

Placement Within Your Coverage Area

Luxul Wireless products, particularly those implementing our patented booster products, are often capable of emitting enough signal strength to cover an entire home regardless of orientation. However, for best results, the deployment suggestions, figure 5, are recommended.

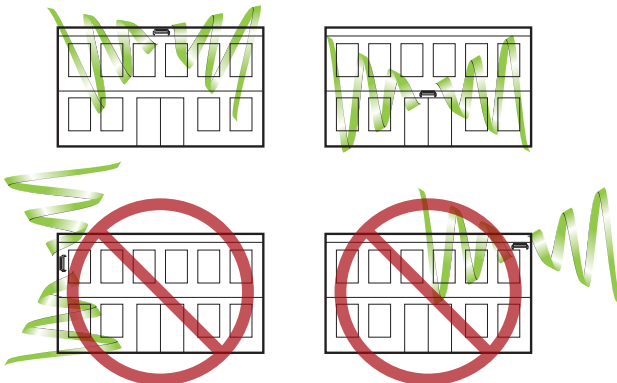

FIGURE 6

QUICK INSTALL GUIDE

Large or Unusually Shaped Coverage Areas

If installing the Wi-Fi Range Extender System in a large or unusually shaped coverage area Figure 7 demonstrates how two antennas can more effectively be aimed into your desired coverage area..

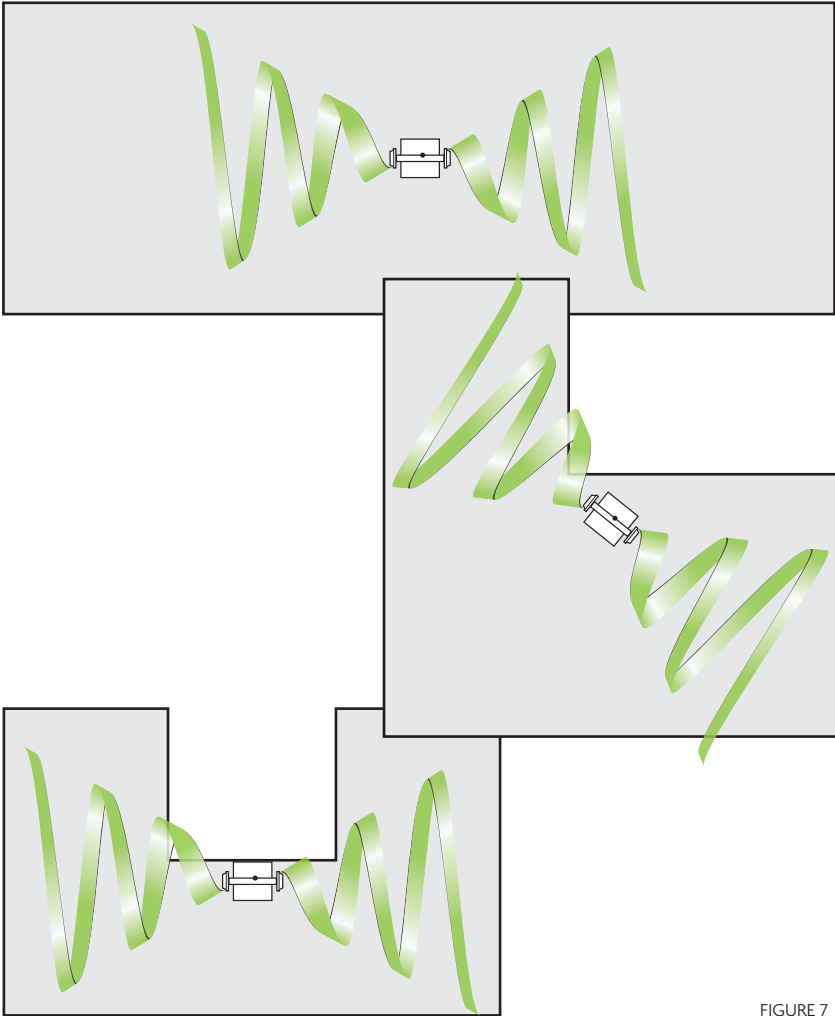

FIGURE 7

TROUBLESHOOTING

Weak or non-existent coverage.

- Make sure the cables are properly connected and that there is power to the Shock-WAV Wi-Fi Signal Booster and your WAP (Wireless Access Point).
- If the Signal Booster is powered the Power and TX/RX indicators will be solid green. If data is passing through the signal booster the TX/RX indicator will be Green with flashing Red. If there is no indication of data pass through remove the Luxul unit and test with the WAPs stock antennas to make sure the WAP's radio is transmitting. If the WAP is not transmitting check your WAP's documentation for possible causes.
- Sometimes, WAP's with multiple antennas have primary and secondary antenna ports. Be sure to connect the signal booster to the primary antenna port of the WAP as many secondary ports are receive only, or do not transmit at the same power level as the primary antenna port. If your WAP has more than one antenna port, try connecting to a different port and/or, if available, change the administration settings disable the secondary antenna port. (See your WAP's documentation).
- Ensure the X-WAV antenna is properly positioned. Directional antennas should face the direction of the area to be covered. Omni antennas should be centered in the desired coverage area. Antennas should have minimum of 2 feet (.6 meters) of clearance with no obstructions.
- The Luxul Wireless Circular Polarized signal is superior for penetrating wood, concrete, and stucco, but all wireless signals can be disrupted by certain obstructions, including large metal objects, or strong magnetic fields. Try orienting the antenna where line-of-sight access to the desired coverage area is available.

After checking the above items, if your Luxul Wireless product still does not seem to be functioning properly, please contact Technical Support at: support@luxulwireless.com
For warranty information please go to: www.luxulwireless.com/warranty/

Results may vary depending on building layout, type of construction and other environmental factors including Wi-Fi traffic, Microwave Ovens, Cordless Phones etc.

FCC NOTICE: The use of all radio equipment is subject to regulations in each country. To comply with FCC part 15 rules in the United States, radio equipment must only be used in systems that have been FCC certified. It is the responsibility of the user/professional installer/operator to ensure that only approved equipment/systems are deployed. To ensure FCC part 15 compliance, Luxul amplifier products should only be installed in certified systems by licensed professionals.

FCC Certification Support for OEMs: Luxul Wireless offers FCC certification assistance and engineering support for qualified OEMs interested in certifying complete amplified WLAN systems. Please contact us for details.

LUXUL WIRELESS | 357 South 670 West, Lindon, UT, 84042
p: 801-822-5450 f: 801-822-5460 | www.luxulwireless.com